

Patented Product

專利產品

REVISIONS

REV	DESCRIPTION	DATE	BY

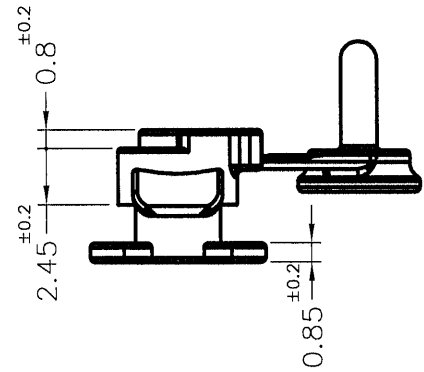
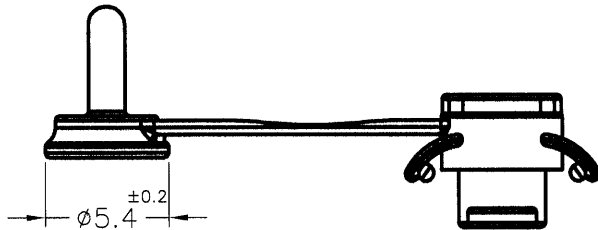
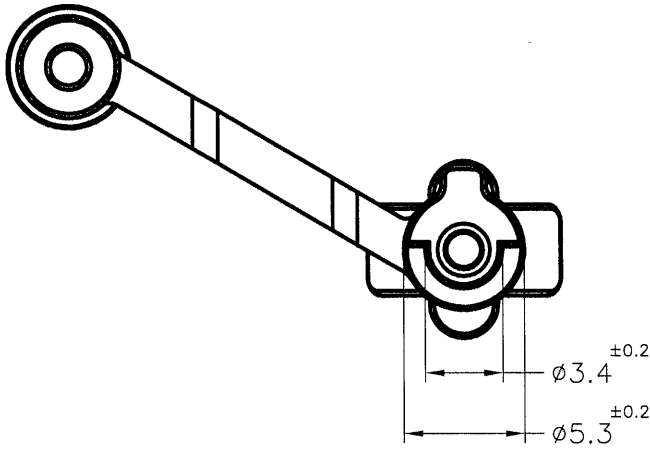

NOTE: 1. MADE OF EQUIVALENT MATERIAL.
 均可使用同等材質。
 2. SHRINKING IS NORMAL STATUS.
 內縮為正常現象。

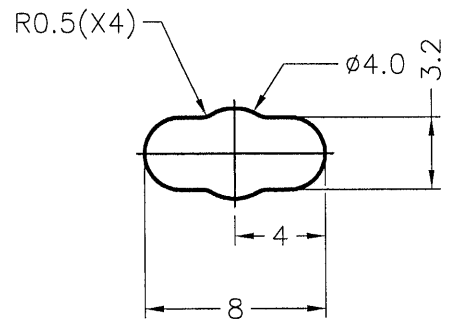

RECOMMEND MOUNTING HOLE
 RECOMMEND THICKNESS: 1.6~1.8mm

 康揚企業股份有限公司 KANG YANG HARDWARE ENTERPRISE CO., LTD. 康揚塑膠(東莞)有限公司 KANG YANG PLASTIC(DONG GUAN) CO., LTD. 康哲電腦配件(吳江)有限公司 KANG CHE COMPUTER COMPONENTS(WUJIANG) CO., LTD.				TITLE	SPACER SUPPORT		SPEC. DWG.	
				MATERIAL	NYLON 66 UL94V-0		DATE	2018.03.12
PART NUMBER				DRAWING NUMBER				
ULCNA2.5-1.8SV0B				ULCNA2.5-1.8S				
FINISH	COLOR		BLACK		DRAWN	L.K.J.		
SIZE	SCALE	UNIT	REV	UNLESS OTHERWISE SPECIFIED TOLERANCE	CHECK	APPROVED		
A4	3:1	mm	A	SEE ABOVE	Will	