

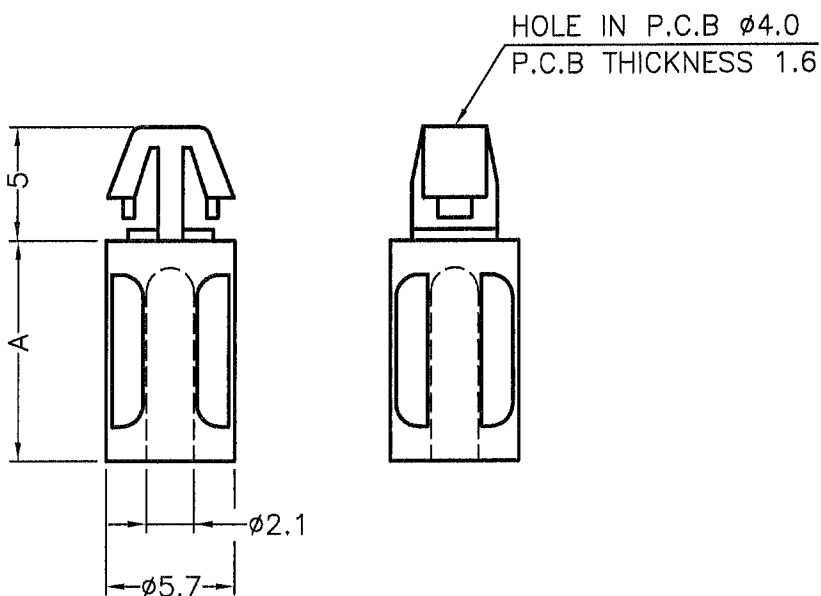

DIM.	TOL.
5mm DOWN	±0.2
5~20mm	±0.3
20~40mm	±0.4
40~60mm	±0.5
60~100mm	±0.8
100mm UP	±1.0

REVISIONS			
REV	DESCRIPTION	DATE	BY



PART NO.	A
MCH-6	6.35
MCH-10	9.7
MCH-12	12.7

NOTE: All measurement does not include gate which raises under 0.3mm.

 <p>康揚企業股份有限公司 KANG YANG HARDWARE ENTERPRISE CO., LTD. 康揚塑膠(東莞)有限公司 KANG YANG PLASTIC(DONG GUAN) CO., LTD. 康哲電腦配件(吳江)有限公司 KANG CHE COMPUTER COMPONENTS(WUJIANG) CO., LTD.</p>	TITLE SPACER SUPPORT		SPEC. DWG	
	MATERIAL NYLON 66 UL94V-2		DATE 1999.05.31	
	FINISH		DRAWN JASON	
	COLOR NATURAL		CHECK 	
PART NUMBER SEE ABOVE	DRAWING NUMBER MCH-H		UNLESS OTHERWISE SPECIFIED TOLERANCE SEE ABOVE	
SIZE A4	SCALE 3:1	UNIT mm	REV A	APPROVED 