

REVISIONS			
REV	DESCRIPTION	DATE	BY

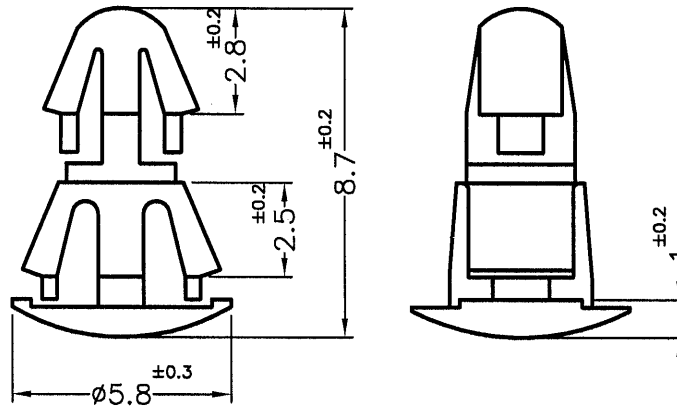

HOLE IN P.C.B $\phi 3.0$
P.C.B THICKNESS 1.6



HOLE IN CHASSIS $\phi 4.0$
CHASSIS THICKNESS 0.6~0.8

PART NO.	MATERIAL	COLOR
RCO-2.5	NYLON 66 UL94V-2	NATURAL
RCO-2.5(B)		BLACK
RCO-2.5V0	NYLON 66 UL94V-0	NATURAL(WHITE)
RCO-2.5V0(B)		BLACK

NOTE: 1. SHRINKING IS NORMAL STATUS.
內縮為正常現象。
2. MADE OF EQUIVALENT MATERIAL.
均可使用同等材質。

 <p>康揚企業股份有限公司 KANG YANG HARDWARE ENTERPRISE CO., LTD. 康揚塑膠(東莞)有限公司 KANG YANG PLASTIC(DONG GUAN)CO.,LTD. 康哲電腦配件(吳江)有限公司 KANG CHE COMPUTER COMPONENTS(WUJIANG) CO.,LTD.</p>				TITLE	SPACER SUPPORT	SPEC. DWG.	
				MATERIAL	SEE ABOVE	DATE	2006.08.14
				FINISH		DRAWN	JOHNNY
PART NUMBER		DRAWING NUMBER		COLOR	CHECK		
SEE ABOVE		RCO-2.5		SEE ABOVE			
SIZE	SCALE	UNIT	REV	UNLESS OTHERWISE SPECIFIED TOLERANCE	APPROVED		
A4	5:1	mm	D	SEE ABOVE	